

PRODUCT DESCRIPTION

- » The compression piece and the counterholder are connected undetachably to the clamping claw
- » Two clamping surfaces - for covering various applications and clamping heights
- » Quick clamping of injection moulds onto injection moulding machines

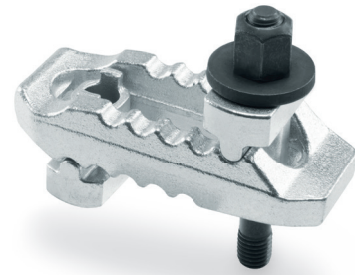
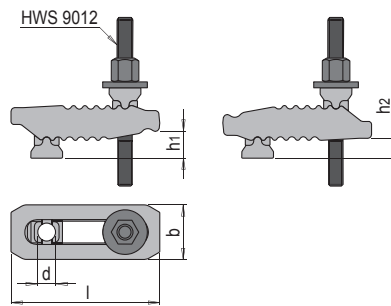

h1	h2	b	l	SK ¹⁾²⁾	HWS 9012	d	No.	EUR
0-30	18	44	115	30	M12x100	13	HWS 120/12/100/13	<>
0-55	18	44	115	30	M12x125	13	HWS 120/12/125/13	<>
0-50	20	55	150	40	M12x125	17	HWS 120/12/125/17	<>
0-70	20	55	150	40	M12x160	17	HWS 120/12/160/17	<>
0-40	20	55	150	40	M16x125	17	HWS 120/16/125/17	<>
0-70	20	55	150	40	M16x160	17	HWS 120/16/160/17	<>
0-40	30	62	187	60	M20x160	21	HWS 120/20/160/21	<>
0-80	30	62	187	60	M20x200	21	HWS 120/20/200/21	<>
0-100	31	70	235	75	M20x250	25	HWS 120/20/250/25	<>
0-50	31	70	235	75	M24x200	25	HWS 120/24/200/25	<>
0-100	31	70	235	75	M24x250	25	HWS 120/24/250/25	<>

1) SK: max. clamping force [kN]

2) The clamping forces given are for the optimal clamping position (smallest possible distance between clamping screw and clamping point).